

Pre-Paint>Fuselage>Empennage>Fit vertical tail fin

Objectives of this task:

To fit the vertical tail fin to the fuselage, including fitting the static probe, static tube, optional strobe light wiring and the VHF antenna coax cable.

Materials and equipment required:

Card # J3 'Rudder' for the VHF antenna

Glass cloth and peel cloth bags labelled: "Tail Fin" and "Outer Reo Tail Fin"

Epoxy resin and flock

5-minute Araldite and flock

2 lengths of 2" aluminium angle, waxed, each one at least the length of the join

Plumb bob and string line

Builders level



Completed vertical fin fitted to the fuselage

Fit the spar extender

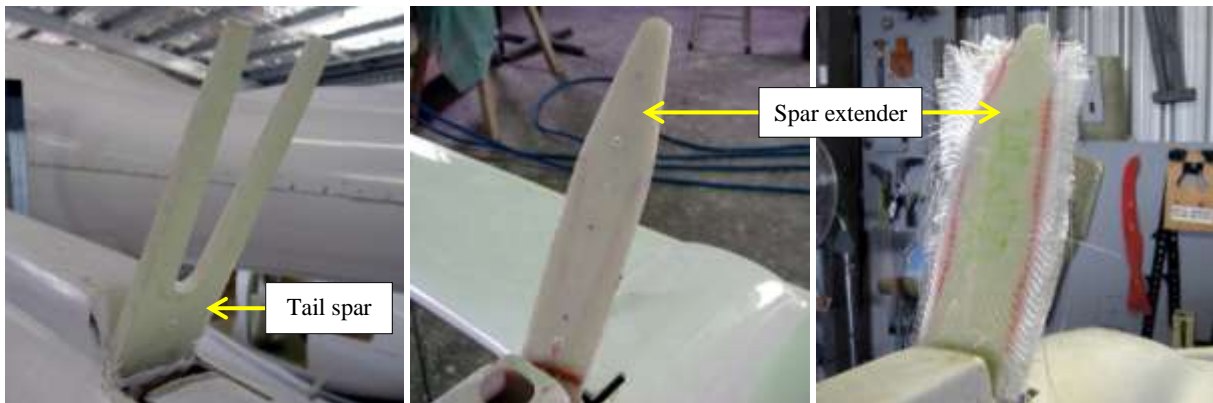

Sand the matching surfaces of the pre-fitted tail spar and the spar extender. Make sure that the 2 pieces match and then fix the spar extender in place with 5-Minute Araldite.

When the Araldite has cured sand the front and back surfaces of the spar, mix a batch of resin and coat both surfaces and then brush on 3 layers of AF303 glass fibre cloth to each surface (front and back) and finish with a layer of peel cloth.

When ready to fit the fin remove the peel cloth and carefully trim the glass cloth from the sides of the extended tail spar. A heat gun will make the edges of the cloth easier to trim with a sharp knife.

Prepare the vertical fin



Start by laying the vertical fin on its side and drilling out the marked inspection hole on the left-hand side with a hole saw.

Turn the vertical fin over and cut out the marked slot for the rudder cable: drill each end of the slot then use

a jigsaw to join the two holes.

Remove any burrs – the exact sizing of the hole and slot will be finalized once the vertical fin has been fitted into place.

Remove the peel cloth from both sides of the joining surface. Use a scraper to remove any edge strips of the peel cloth that have not peeled off cleanly.



Using a round file, enlarge the static probe mount hole in the top front of the fin – it needs to be large enough to pass the static tube and draw wire through easily. The finished hole size is not critical. Take care not to file through the pre-installed drawstring: for this reason using a drill is not recommended. If fitting the optional strobe to the top of the fin then you should fit the mounting base now: flock the base to the forward top of the fin and screw in place.

Pull the static tube and the VHF cable through the fin

Lay the vertical fin beside the fuselage on trestles set at about the same height as the fin mounting stub. Lay the strake across the mounting stub.

Locate the drawstring inside the fin that will be used for the VHF cable and the static tube – it is tied in a loop around the internal foam rib. Cut the bottom of the loop to separate the drawstring into 2 parts: the static tube/strobe wiring and the VHF cable.

Run the static tube/strobe wiring up from the fuselage into the rear section of the fin, **through** the hole in the internal foam rib and into the front section of the fin – do **not** let the static tube lay under the rib or it will be squashed against the stub when the fin is fitted. *This is critical!*

Tie a length of wire to the static tube drawstring and pull it through – the friction of the static tube being pulled may cause a string to break.

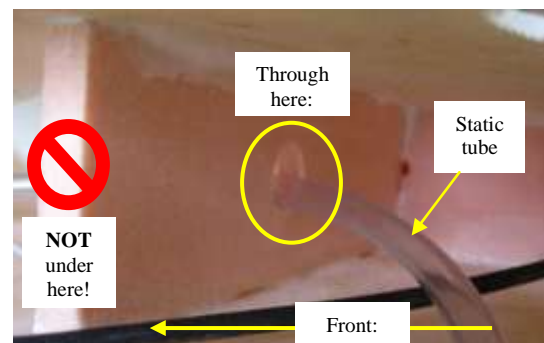



Tie the drawstring to the VHF cable and the draw wire to the static tube/strobe wiring. The photos below show how: loop the draw string or wire around the cable or tube to be pulled then tape the end of the draw wire or string so that when it is pulled it will tighten the knot. Tape the end of the cable or tube to be pulled to streamline it and avoid it catching on anything. Cloth tape is stronger than masking tape and is recommended for this purpose.



Pull the static tube/strobe wiring and the VHF cable through the fin and out of their respective holes, then tie a knot or tape a mixing stick across the end at right angles to prevent them sliding back inside the fin.

Test fit the vertical fin

Tape the rudder cable threads then push the cable forwards until it can be tucked inside the slot in the mounting stub. Lift the fin up and over the tail spar and slide the fin down into place. You may have to trim a small amount out of the fuselage behind the tail spar to clear the fin spar. A jigsaw is ideal for this task.



Check the fit along the entire joining line and mark and remove as required to achieve a good fit. Take extra care to ensure that the join at the front of the strake (at the yellow arrow in the photo below) is smooth so that there is one continuous line along the entire length of the strake – if there is any discontinuity it will look extremely disappointing when paint is applied so take care to get it exactly right at this time.

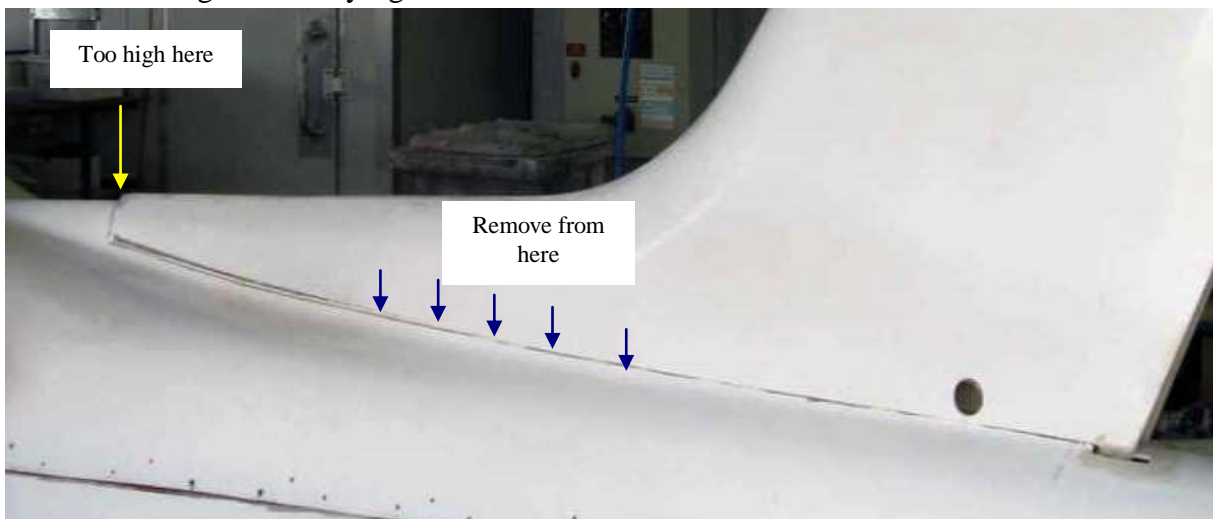



Level the aircraft

Because the alignment of the vertical fin is important the aircraft should be fixed in a “wings level” attitude prior to the final fit. Place a 3” block on the top of each front wing mounting lug and place a spirit level across the top of the cabin so that it rests on both blocks. Pack the main wheels as required to level the aircraft.



Fit the vertical fin

You will need a second person to help you position and fit the vertical fin.

When you are satisfied that the fin will fit correctly, prepare the mounting stub on the fuselage by sanding all of the gel coat from the surface of the joggle.

Lightly sand the inner surface of the vertical fin and the mating surfaces of the tail spar and fin spar.

Mix a batch of resin and carefully coat all surfaces to be joined. Add flock and mix, then apply a 3 – 5mm coat to one side of all surfaces to be joined: both sides of the mounting stub and the back of the tail spar.



Do not be overly concerned about getting a precisely even layer of flock – the pressure of the 2 surfaces being squeezed together will ensure that the flock is evenly distributed.

With one person holding each side of the vertical fin, lift the fin into position and lower it down while holding the sides of the fin apart as shown below.



Take care not to let the fin just slide down into place because it will push all the flock out of the join, and do not let the fin slide down past the joggle! You may want to fit 2 x self-tapping screws at either side of the rear of the empennage just where the joggle steps out to prevent this happening.

When the fin is all the way down push the fin all the way forward and allow the sides to push in and onto the flock. Check the fit, particularly at the strake/fuselage join.

Tie a plumb bob to a string line and fix the string line to the top of the vertical fin then align the fin until it is *precisely* vertical: the string line should be exactly in the centre of the fin when viewed from the rear. **Recheck this vertical alignment** at every step from here on.



Once the alignment is correct, secure the fin in position. You could use a strip of heavy adhesive tape from the outside edge of the horizontal fin, over the top of the vertical fin and down to the other side of the horizontal fin. **Recheck the vertical alignment.**

Now hold the fin forward and fix the fin spar to the tail spar with 2 self-tapping screws as shown at right. **Recheck the vertical alignment.**



Rivet the front of the strake into place with a countersunk pop rivet at each side of the strake and then rivet at each side of the inspection hole and the rudder cable and remove the self-tapping screws. **Recheck the vertical alignment.**

Wax one side of each of 2 lengths of aluminium channel so that the flock will not stick and place as a rail along each side the full length of the join line and secure with clamps as shown below. **Recheck the vertical alignment.** Leave overnight to cure.



Next day remove the aluminium channels and the peel cloth, then use a hole saw to open the inspection hole and a drill and jigsaw to recut the rudder cable slot. File out any rough edges.

Fit the VHF antenna

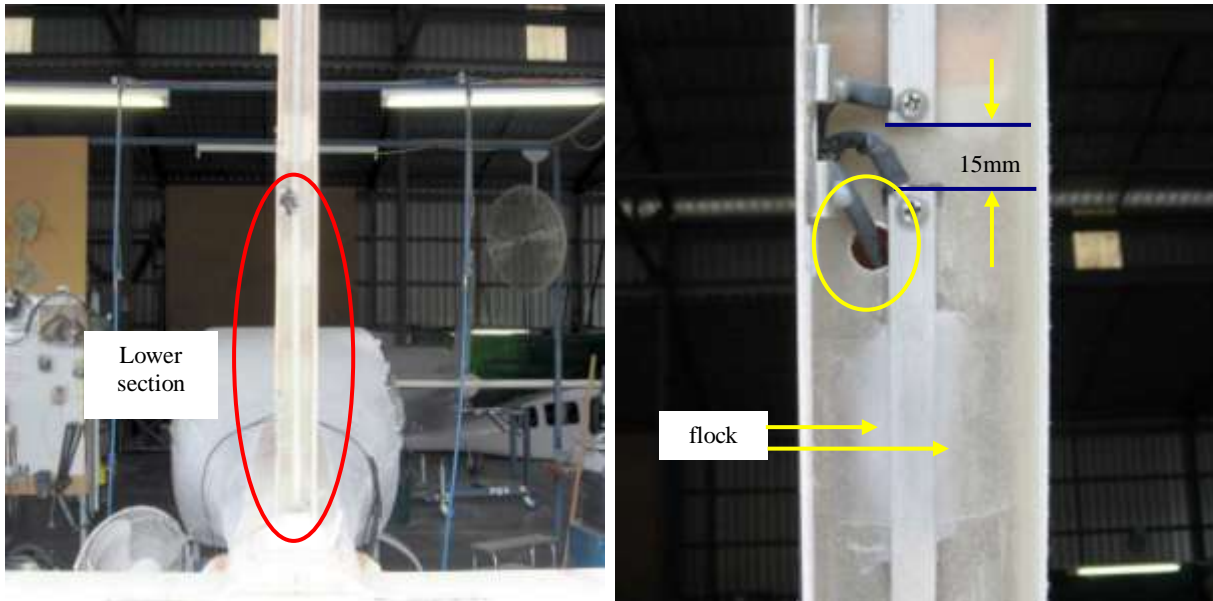

Ensure that the VHF coax cable exit hole is on the hinge (left-hand) side of the vertical fin – elongate the hole with a file if it is not. Sand the back of the lower section of the VHF antenna and place it so that it is exactly 15mm below the upper section and fix it in place with 5-minute Araldite.

Note that the factory fitted upper section of the antenna has been offset slightly to the left to allow for rudder movement: keep the lower section of the antenna exactly in line vertically with the upper section.

Ensure that the threaded hole for the electrical connection is at the top of the lower section as shown above right.

Mix some resin and lay up 2 pieces of glass fibre cloth across each section of the antenna in 3 places, using flock to fill the gaps at each side of the antenna before placing the cloth. Leave overnight to cure.

Next day, shorten the VHF coax cable to length, and fit ferrite toroids, crimp 4.5mm electrical ring terminal connectors to the inner cable and the outer coax sheath and fit heat shrink tubing over the terminal joins, as shown in the sketch below.

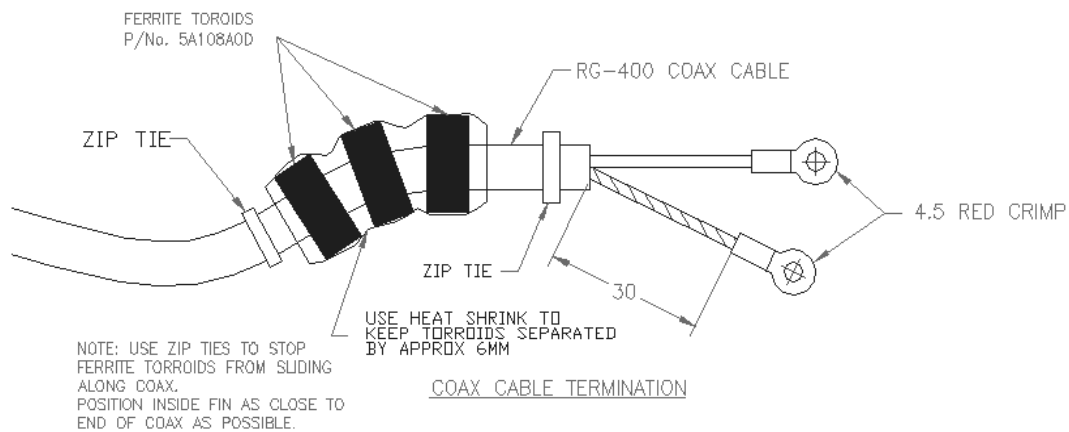

Screw the inner cable to the TOP section and the braided coax sheath to the LOWER section. Tuck any excess cable back into the vertical fin and seal completely with silicone sealant.



Fit the static probe assembly

Assemble the static probe: using a drop of Loctite fit the bullet-nose end to the static tube, making sure that the vent hole (circled) will be horizontal when the static probe is installed.

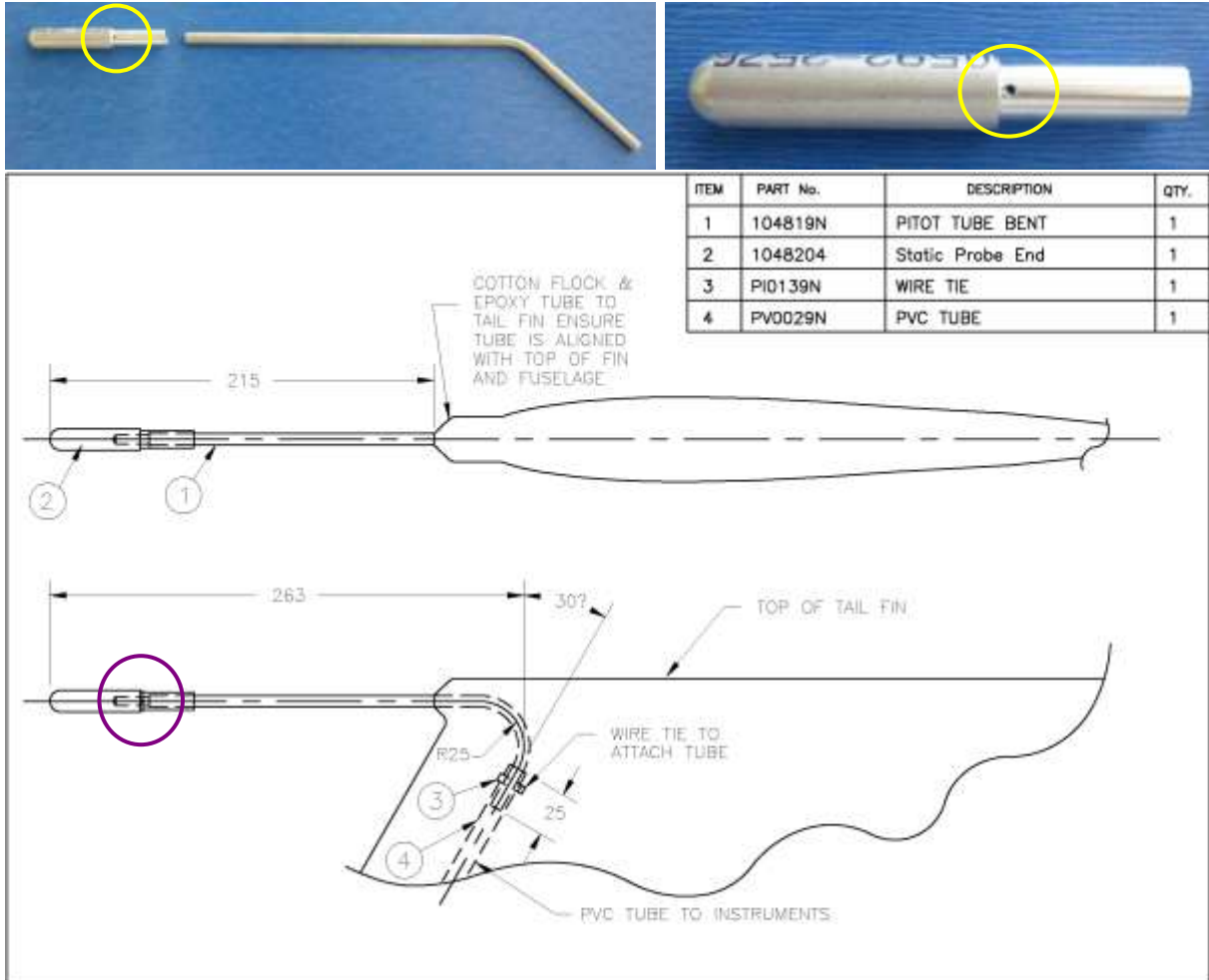

Put a smear of super glue around the base of the static tube then slide the PVC tube over the base of the static tube by at least 25mm and fix firmly in place with 2 lock wire ties.

Take particular care that the PVC tube is well secured to the static tube because once the static probe assembly has been flocked in place there will be no access for repair work.

Push the static probe assembly back into the hole at the front top of the vertical fin so that the static probe assembly is parallel with the top of the vertical fin and centred laterally in the fin.

Secure the static probe assembly in place with 5-minute Araldite and hold it in place while the Araldite dries. Mix up a batch of resin and coat the area around the base of the static probe assembly, and then add some flock to make a firm mix and shape around the base of the static probe assembly to form a smooth transition from the static probe to the fin. Leave to cure overnight and then sand to a smooth tapered finish.

This completes the *Pre-Paint>Fuselage>Empennage>Fit vertical fin* task.