

Pre-Paint>Fuselage>Interior>Console>Pre-fit handbrake

Objectives of this task:

To pre-fit the handbrake master cylinder and lever to the centre console. At the completion of this task the handbrake will be removed and stored until final fitting following painting and installation of the interior trim.

Completed handbrake master cylinder, handbrake lever and locking cam, as viewed from the right-hand side ►

Materials required:

Card # J8 'Brakes'

Loctite 577

Fit the master cylinder

Using a small bead of Loctite 577 on the thread, attach the brass compression fitting to the master cylinder and tighten firmly. Put a piece of masking tape over the hole to keep foreign objects out.

Drill the upper and lower mounting holes out to 5/16" (arrowed below), then, working through the side access holes in the console, fit the brake lever mount into the front of the console (refer to drawing 6A027A0D-3 on the next page for detail) using two hex head bolts in the top and bottom holes, then mount the master cylinder to the brake lever mount with the cap screws– the photo at right shows the orientation of the components: note that the brake lever mount has the pivot hole to the top.

The photos below show the fitting of the brake lever mount and the master cylinder to the console.

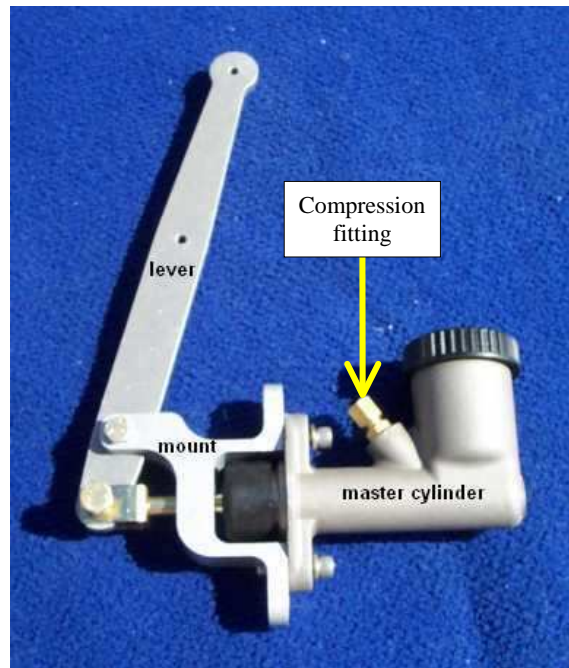

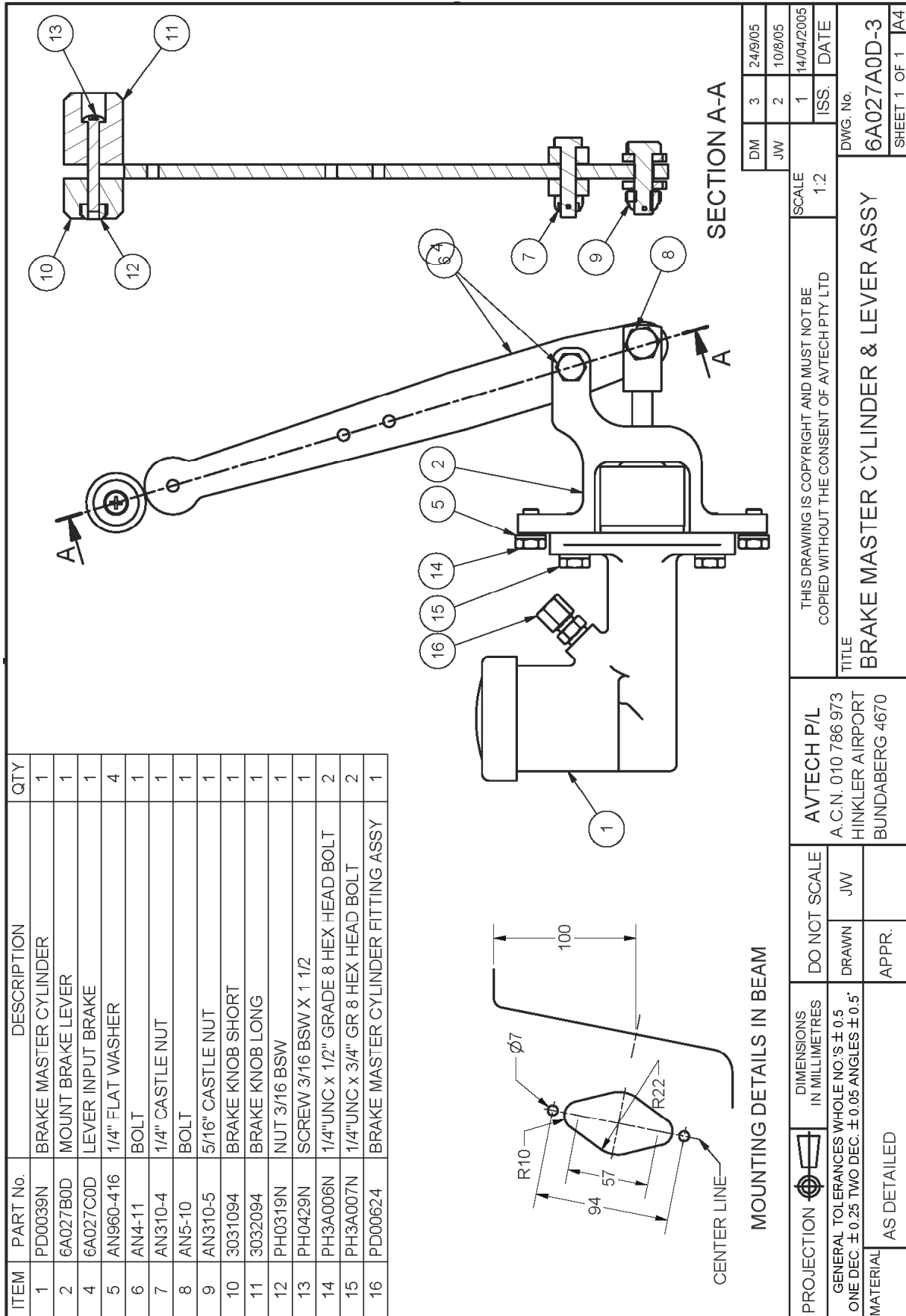

DM	3	24/9/05
JW	2	10/8/05
ISS	1	14/04/2005
DATE		

SCALE	1:2
THIS DRAWING IS COPYRIGHT AND MUST NOT BE COPIED WITHOUT THE CONSENT OF AVTECH PTY LTD	
TITLE	
BRAKE MASTER CYLINDER & LEVER ASSY	
DWG. No. 6A027A0D-3	
SHEET 1 OF 1	

AVTECH P/L
A.C.N. 010 786 973
HINKLER AIRPORT
BUNDABERG 4670

DO NOT SCALE
DRAWN JW
APPR.

PROJECTION	DIMENSIONS IN MILLIMETRES
GENERAL TOLERANCES WHOLE NO.'S ± 0.5	
ONE DEC. ± 0.25 TWO DEC. ± 0.05 ANGLES $\pm 0.5^\circ$	
MATERIAL	AS DETAILED



Fit the handbrake lever

Assemble the two red knobs to the handbrake lever, with the longer knob to the left of the lever (the same side as the machined recess) and secure with the supplied bolt and nut.

Fit the handbrake lever cam to the right-hand side of the handbrake lever with the supplied bolt and Nyloc nut and with a ¼” Bundy tube bush in place to allow free movement of the handbrake lever locking cam.

The lever assembly can now be fitted to the brake lever mount. It may be necessary to file the cut-out on top of the console in order to achieve full fore and aft travel of the handbrake lever as well as the correct side clearance for the handbrake lever locking cam.

Check that the handbrake lever has full movement and that the handbrake lever locking cam does not bind against the sides of the console cutout, then remove the entire handbrake assembly and put aside until the *Paint* and *Interior Trim* tasks have been completed.

This completes the *Pre-Paint>Fuselage>Interior>Console>Pre-fit handbrake* task.