

JABIRU AIRCRAFT PTY LTD

P.O. Box 5186
Bundaberg West
Queensland, Australia.

Phone: +61 7 4155 1778
Fax: +61 7 4155 2669
Email: info@jabiru.net.au

SERVICE BULLETIN: JSB 031-1

Issue: 1

Date: 14th April 2011

Subject: Jabiru Engine Through-Bolts

1 Table of Contents

1	TABLE OF CONTENTS	1
2	APPLICABILITY	1
3	BACKGROUND	2
3.1	GENERAL	2
3.2	CONTRIBUTING FACTORS	3
3.3	CORRECTIVE OR PREVENTATIVE MEASURES	3
4	REQUIREMENTS:	4
4.1	ANY ENGINE AT OVERHAUL OR MAJOR MAINTENANCE	4
4.2	ANY ENGINE WHICH HAS PREVIOUSLY SUFFERED THROUGH-BOLT FAILURE	4
4.3	ENGINES WITH LESS THAN 500 HRS TTIS OR LESS THAN 200 HRS TSO	5
4.4	ENGINES WITH 500 – 1000 HRS TTIS OR MORE THAN 200 HRS TSO	5
5	COMPLIANCE:	5
5.1	ANY ENGINE WHICH HAS PREVIOUSLY SUFFERED THROUGH-BOLT FAILURE	5
5.2	ENGINES WITH LESS THAN 500 HRS TTIS OR LESS THAN 200 HRS TSO	5
5.3	ENGINES WITH 500 – 1000 HRS TTIS OR MORE THAN 200 HRS TSO	5
6	PROCEDURES	6
6.1	USING 12-POINT NUTS	6
7	AIRWORTHINESS NOTE:	7
7.1	GENERAL	7
7.2	GENERAL ENGINE MAINTENANCE NOTES	7

2 Applicability

- The content of this bulletin is applicable to the following Jabiru 2200 and 3300 engines:
 - a) 2200A S/No. 1707 to 3483
 - b) 2200B S/No. 001 onwards*
 - c) 2200C S/No. 001 onwards*
 - d) 2200J S/No. Depends on configuration. Contact Jabiru Aircraft Australia for details.
 - e) 3300A S/No. 637 to 2391
 - f) 3300L S/No. 001 onwards*

* - These serial number ranges are current at the time of writing. They will alter in the future. If in doubt please contact Jabiru Aircraft Australia.

Jabiru Service Bulletin: Jabiru Engine Through-Bolts

JSB 031-1

14th April 2011

Notes:

- i. For aircraft in Light Sport Aircraft categories this Bulletin is equivalent to a Manufacturer's Safety Direction.
- ii. This bulletin has not been mandated (as an AD or similar) by any National Airworthiness Authority at the time of writing.

3 Background

3.1 General

- All Jabiru Engines are assembled using a combination of Through-Bolts and Studs – as shown in Figure 1 below. The number of through-bolts varies depending on which engine model is considered but there are always 6 studs (not all with the same part number). The through-bolts and studs hold the cylinders in place and the halves of the crankcases together.
- Recently there have been some cases of these bolts failing in service, leading to engine failure.
- This bulletin has been introduced to provide upgrade options to operators to address potential issues with their engines.

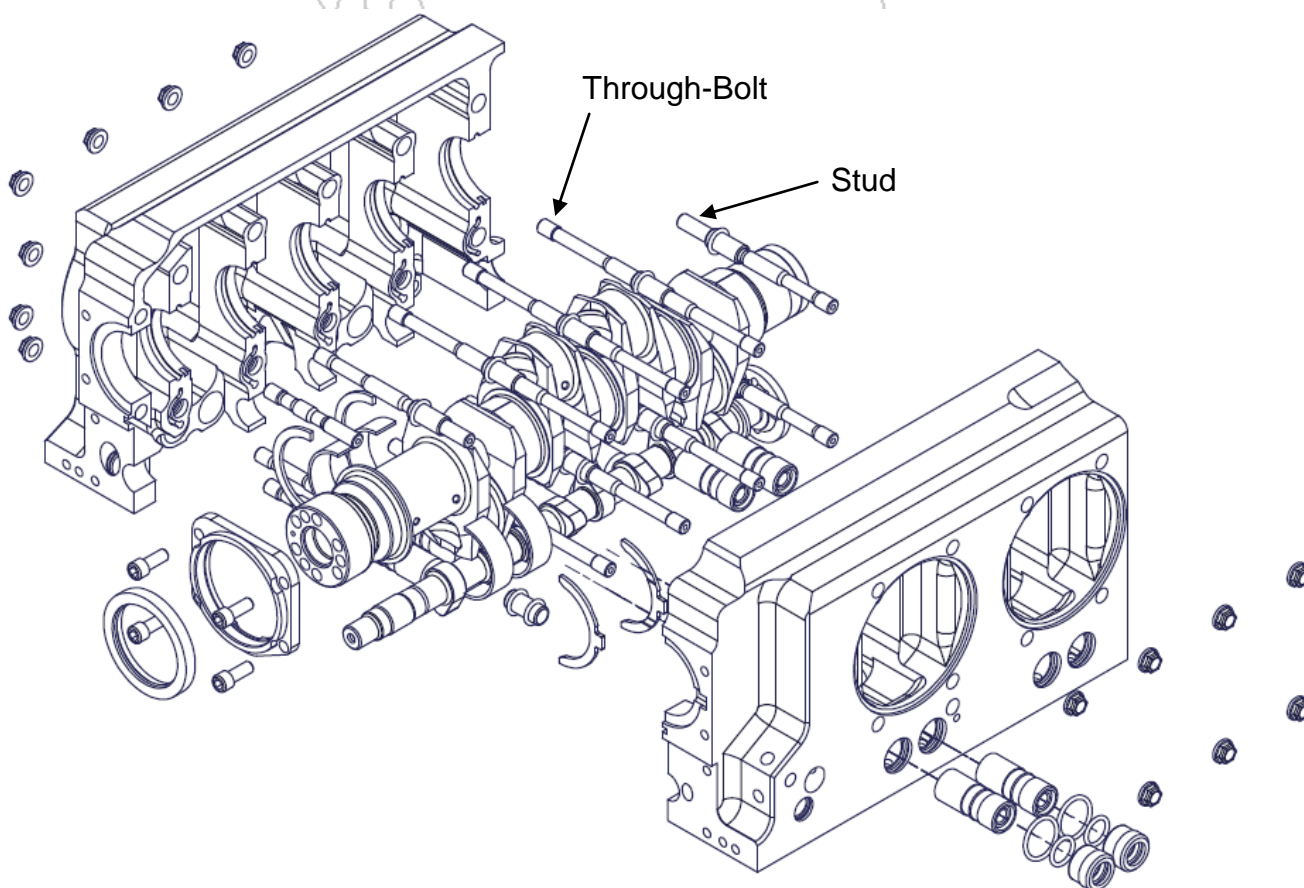

Figure 1 – General Engine Layout

Jabiru Service Bulletin: Jabiru Engine Through-Bolts

JSB 031-1

14th April 2011

3.2 Contributing Factors

- A number of factors can contribute to through-bolt failure. The following list contains a few examples but there are many other, smaller, factors which can have an impact.
 - a) **Detonation or uneven combustion.** Detonation or uneven combustion can be caused by incorrect tuning, induction system leaks, stale or incorrect fuel or a number of other factors. The result is increased engine vibration.
 - b) **Operation.** Engines which work hard with high engine temperatures tend to have more issues than others.
 - c) **Maintenance.** In some cases through bolt failures have been caused when a person has tightened them beyond the design tension. Poorly calibrated torque wrenches and poor understanding of tools like the “crowsfoot” torque wrench extension also contribute.

3.3 Corrective or Preventative Measures

- Testing has shown that 12-point nuts (Figure 2) can carry a slightly higher load than the original MS21042 type nuts. As they are longer they also spread the tension load over a higher number of threads on the bolt. This reduces the load concentrated on any given thread and improves the ultimate strength and fatigue life of the assembly.
- New case assembly hardware has been developed which uses a larger (7/16”) thread. This increases the effective diameter of the bolt and again, reduces the peak stress in the part. This improves the ultimate strength and fatigue life of the assembly.
- The fit of the crankcase locating dowels has been altered to provide more positive location for the case halves. This allows the assembly to absorb potentially damaging vibration without putting excess stress on the case assembly hardware.
- Shims are available which, when fitted under the cylinder barrels of the engine, reduce the compression ratio. This allows the engine to be more tolerant of poor fuels.
- Jabiru Aircraft have recently completed and released a detailed Overhaul Manual for the 2200 and 3300 engines. Anyone performing major maintenance on one of these engines must familiarize themselves with this manual and follow its recommendations. Like the other engine manuals this manual will be updated periodically with new information and the latest version is available from our website – www.jabiru.net.au
- Operating techniques can also be altered to be more sympathetic to the engine. Suggestions include:
 - a) Increase the speed of the aircraft in climb. Many operators automatically stabilize the aircraft at the best rate of climb speed in climbs. While this provides optimum aircraft performance it is not the ideal operating regime for the engine. For Jabiru aircraft with a 4-cylinder engine an in-climb speed of around 80 knots normally provides climb performance close to the airframe optimum but at the same time giving significantly improved engine cooling. For a 6-cylinder Jabiru aircraft the rate of climb generally varies only slightly between low and high speeds – with a speed of about 90 knots giving a rate of climb very close to peak performance but again, while providing improved engine cooling. Increasing the aircraft speed also allows the engine RPM to increase which tends to reduce the stress on many engine components and makes detonation or uneven combustion less likely. Obviously these recommendations are for situations where a slight reduction in climb performance makes no difference – in safety-critical situations the best rate of climb or best angle of climb speed should be used.

Jabiru Service Bulletin: Jabiru Engine Through-Bolts

JSB 031-1

14th April 2011

- b) Take extra care with fuel. Jabiru Service Letter JSL007 (Issue 3 or later) provides a lot of information on what fuels are recommended for Jabiru engines. Operators should familiarise themselves with it and follow its recommendations.

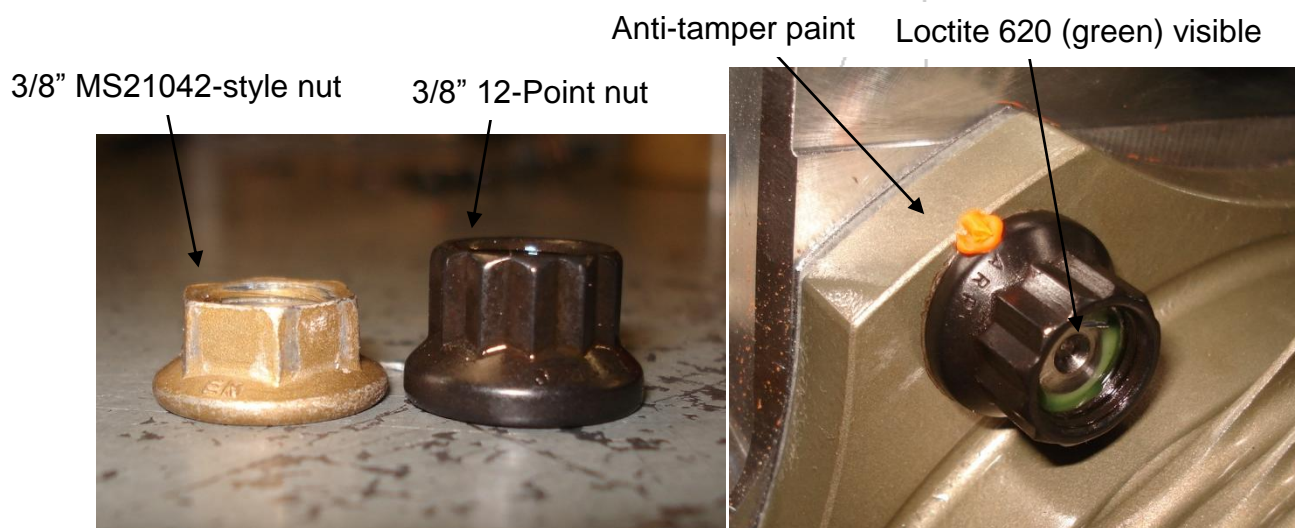

Figure 2 – 12-Point Nuts

4 Requirements:

4.1 Any Engine at Overhaul or Major Maintenance

- Any engine which is being overhauled or having major maintenance carried out should be upgraded as follows:
 - a) The existing MS21042 style nuts must be replaced with 3/8" 12-point nuts.
 - b) If the through-bolts currently fitted to the engine have less than 1000 hours TTIS and are not expected to exceed 1000 hours TTIS after this work then the original through-bolts may be re-used. Otherwise they must be replaced. Through-bolts and studs currently have a life of 1000 hours TTIS (see Overhaul Manual for details). Note that the length of these parts has been increased to suit the 12-point nuts and so the replacement parts will be slightly longer than the originals.
 - c) New, oversize crankcase dowels must be fitted. Oversize dowels must accurately match the crankcase dowel bores of the engine. Crankcases must be accurately measured before ordering & more than 1 dowel size may be required in a given engine. Several oversize dowel sizes are available from Jabiru Aircraft or our local representative.
 - d) Refer to the Overhaul Manual for other mandatory replacement items.
- This is a one-off job. Once this work has been carried out the engine can continue to its next scheduled maintenance as normal.

4.2 Any Engine Which Has Previously Suffered Through-Bolt Failure

- The following is required at the interval given in Section 5.1.
 - a) The existing MS21042 style nuts must be replaced with 3/8" 12-point nuts.
 - b) New through-bolts and studs must be fitted.
 - c) New, oversize crankcase dowels must be fitted. Oversize dowels must accurately match the crankcase dowel bores of the engine. Crankcases must be accurately measured

Jabiru Service Bulletin: Jabiru Engine Through-Bolts

JSB 031-1

14th April 2011

before ordering & more than 1 dowel size may be required in a given engine. Several oversize dowel sizes are available from Jabiru Aircraft or our local representative.

- This is a one-off job. Once this work has been carried out the engine can continue to its next scheduled maintenance as normal.

4.3 Engines with Less Than 500 Hrs TTIS or Less Than 200 Hrs TSO

- Note that a “Top End Inspection” as defined in the Overhaul Manual is considered an Overhaul for the purposes of this Bulletin.
- The following is required at the interval given in Section 5.2.
 - a) The existing MS21042 style nuts must be replaced with 3/8” 12-point nuts.
- This is a one-off job. Once the new nuts are fitted the engine can continue to its next scheduled maintenance as normal.

4.4 Engines with 500 – 1000 Hrs TTIS or More Than 200 Hrs TSO

- Note that a “Top End Inspection” as defined in the Overhaul Manual is considered an Overhaul for the purposes of this Bulletin.
- The following is required at the interval given in Section 5.3.
 - a) The existing MS21042 style nuts must be replaced with 3/8” 12-point nuts.
 - b) The through-Bolts and studs must be replaced.
- This is a one-off job. Once the new hardware is fitted the engine can continue to its next scheduled maintenance as normal.

5 Compliance:

- Where calendar time spans are given below, the start date is taken to be the date of first issue of this Service Bulletin - 14th April 2011.

5.1 Any Engine Which Has Previously Suffered Through-Bolt Failure

- Carry out the work detailed in Section 4.2 within the next 100 hours TIS or 12 months, whichever is the sooner.

5.2 Engines with Less Than 500 Hrs TTIS or Less Than 200 Hrs TSO

- Carry out the work detailed in Section 4.3 within the next 100 hours TIS or 12 months, whichever is the sooner.

5.3 Engines with 500 – 1000 Hrs TTIS or More Than 200 Hrs TSO

- Carry out the work detailed in Section 4.4 within the next 200 hours TIS or 12 months, whichever is the sooner.

6 Procedures

- While some special detail is given below the Jabiru Engine Overhaul Manual is the primary source of guidance for these jobs. It must be referred to for all detailed procedures.

6.1 Using 12-Point Nuts

- If the 12-point nuts are used on the original through-bolts then they will overhang the studs as shown in Figure 2 (right) due to their extra length. Normal aircraft practice is to ensure that a minimum of around 1.5 threads project through the nut, however in this case that is not necessary. Figure 3 shows an illustration of 3 through-bolts fitted to an engine. It can be seen that the thread projects the required amount from the old MS21042-style nut but is recessed inside the 12-point nut. However, due to its extra length the 12-point nut is actually engaging with at least 1.5 – 2 threads more and produces a stronger connection. Also, during assembly with “short” through-bolts it is necessary to put one nut in position and then lock it there by screwing a 3/8” UNF bolt into the recess so that the nut on the other end of the stud can be tightened (with the MS21042 style nuts the same thing was achieved by screwing a second nut onto the protruding thread as a lock nut).
- The base of the 12-point nuts must still be lightly chamfered when used on older cylinder barrels to clear the radius at the base of the cylinder. Newer cylinders, like that shown in Figure 2 (right) are a different design and may not need chamfered nuts – but overhaulers must confirm this before final assembly.
- Because these nuts are not self-locking Loctite 620 must be used. Loctite 620 is used because of its strength at elevated temperatures and because it does not act as a strong lubricant when tightening the nut. Using a locking compound on these nuts forces a new installation technique:
 - a) Assemble the engine and tighten all through-bolts and studs to 20lb.ft **without** locking compound.
 - b) Starting from the middle cylinders, remove both nuts from one through-bolt, clean, prime, apply Loctite 620 (approximately the size of 2 match heads applied to threads only – do not apply to flange of nut) and tighten. This must be done quickly, before the Loctite starts to cure. Torque settings are given in the engine overhaul manual.
 - c) Mark the completed nuts with anti-tamper paint as shown in Figure 2 (right).
 - d) Repeat this process on all the remaining through-bolts and studs, working outwards from the middle cylinders as normal.

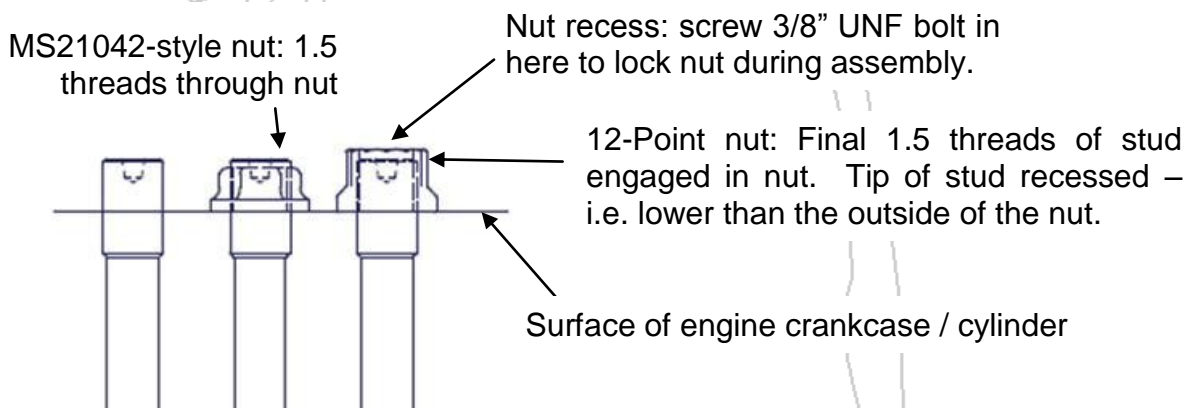

Figure 3 – Through-Bolt Thread Illustration With Original Through-Bolts & Studs

Jabiru Service Bulletin: Jabiru Engine Through-Bolts

JSB 031-1

14th April 2011

7 Airworthiness Note:

7.1 General

- Where required, work called for by this Bulletin must be carried out by authorised personnel only. In Australia this generally means the original builder of an Experimental-category aircraft (either RA-Aus or VH registered), an RA-Aus Level 2 holder for other RA-Aus aircraft or a Licensed Aircraft Maintenance Engineer (LAME).
- On completion of the work, the authorised person must note the completion of the actions required by this bulletin in the aircraft or engine's maintenance logbook. This note should refer to the completion of maintenance requirements of this Service Bulletin, indicate the date of the work and the identity (including licence number where appropriate) of the person carrying out the work.

7.2 General Engine Maintenance Notes

- **The work detailed in this Bulletin requires extensive skills, experience and training in engine maintenance – as well as special tools and equipment. Unskilled personnel or those lacking the correct tools and training must not attempt this work.**
- Always take care while working around the propeller – ensure the ignitions are turned OFF and that no-one is in the cockpit while working on the engine.
- Always use a good quality tension wrench.
- It is strongly recommended to check the accuracy of tension wrenches at least every year.
- Refer to the engine overhaul manual for details of how to use a “crowsfoot” adaptor.
- Loctite 620 is an extreme strength, high temperature grade designed to retain bearings. Care must be taken when using to only use as much as required. Removing bolts which have been retained with Loctite 620 can normally be achieved by heating the bolt to over 150°C using a pencil-point gas burner. Work quickly! Loctite 620 cures quickly, especially if cure accelerator is used. **Tensions must be set on parts before the Loctite begins curing.**

Safety Directive: **JSD 031-1**
Issue: **1**
Date: **14th April 2011**
Subject: **Jabiru Engine Through-Bolts**

Applicability:

- The content of this directive is applicable to the following Jabiru 2200 and 3300 engines:
 - a) 2200B S/No. 001 onwards*
 - b) 3300A S/No. 637 to 2391
 - c) 3300L S/No. 001 onwards*

* - These serial number ranges are current at the time of writing. They will alter in the future. If in doubt please contact Jabiru Aircraft Australia.

Requirement:

- Operators of engines in the Serial Number ranges given within Light Sport Aircraft categories must comply with the requirements of Jabiru Service Bulletin JSB 031-1

Compliance:

- The compliance details given in JSB 031-1 must be met.

Background:

- This Safety Directive has been prepared to make mandatory the requirements of JSB 031-1 for engines operating within Light Sport Aircraft Categories.